



SERVICE BULLETIN

MODIFICATIONS OF THE OVERFLOW BOTTLE FOR ROTAX® ENGINE TYPE 912 AND 914 (SERIES)

SB-912-039

SB-914-025

MANDATORY

Repeating symbols:

Please, pay attention to the following symbols throughout this document emphasizing particular information.

- ▲ **WARNING:** Identifies an instruction, which if not followed, may cause serious injury or even death.
- **CAUTION:** Denotes an instruction which if not followed, may severely damage the engine or could lead to suspension of warranty.
- ◆ **NOTE:** Information useful for better handling.

1) Planning information

1.1) Engines affected

All versions of the engine type:

- 912 A to S/N 4,410.479
- 912 F to S/N 4,412.820
- 912 S to S/N 4,922.810
- 914 F to S/N 4,420.316

if they have the genuine ROTAX® overflow bottle part no. 922325. In case of doubt, contact your aircraft manufacturer.

1.2) Concurrent ASB/SB/SI and SL

Further to this Service Bulletin, the following additional Service Letters must be observed and complied with: SL-912-009, SL-914-008 "coolant" current issue.

1.3) Reason

Field experience has shown that the coolant can start to boil due to one or several of the following causes.

- Inadequate or defective cooling system.
- Particulates forming in the antifreeze. Ratio of antifreeze/water not as recommended by the manufacturer. See the latest edition of the 912/914 Series Operator's Manual on this.
- The maximum engine operation threshold has been exceeded.

This may lead to a pressure increase in the overflow bottle due to the high coolant temperature. This overload can create damages to the cooling system and as a result, damage the engine. Increasing the size of the vent hole in the plug screw of the overflow bottle can prevent such an increase.

1.4) Subject

Modification of the overflow bottle.

1.5) Compliance

- at the next 100^h inspection, but at the latest by April 1st 2003. The modification of the overflow bottle must be conducted according to the instructions provided in section 3 of this Service Bulletin.

1.6) Approval

The technical content of this Service Bulletin has been approved by ACG.

1.7) Manpower

None

d01881

1.8) Mass data

Change of weight - - - none.
Moment of inertia - - - unaffected.

1.9) Electrical load data

No change

1.10) Software accomplishment summary

No change

1.11) References

In addition to this technical information refer to current issue of
- Operator’s Manual (OM)
- Maintenance Manual (MM)

1.12) Other publications affected

None

1.13) Interchangeability of parts

Not affected.

2) Material Information

Two possible options are available for this modification. With option number 1, no additional material is necessary.

2.1) Material - cost and availability

Price and availability will be supplied on request by ROTAX[®] Authorized Distributors or their Service Center.

2.2) Company support information

None

2.3) Material requirement per engine

Parts requirement for the modification of the cap, option 2:

Fig.no.	New p/n	Qty/engine	Description	Old p/n	Application
-	242213	1	hex. screw M6	-	cooling system
-	940557	1	hose nipple M6	-	cooling system

2.4) Material requirement per spare part

None

2.5) Rework of parts

Modification of overflow bottle cap.

2.6) Special tooling/lubricant-/adhesives-/sealing compound - Price and availability

Price and availability will be supplied on request by ROTAX[®] Authorized Distributors or their Service Centers.

Fig.no.	New p/n	Qty/engine	Description	Old p/n	Application
-	-	N.B	LOCTITE [®] 603	899789	cap

■ CAUTION: In using these special tools observe the manufacturer’s specifications.

3) Accomplishment / Instructions

Accomplishment

All the measures must be taken and confirmed by the following persons or facilities:

- ROTAX[®] -Airworthiness representative
- ROTAX[®] -Distributors or their Service Centers
- Persons approved by the respective Aviation Authority

▲ **WARNING:** Proceed with this work only in a non-smoking area and not close to sparks or open flames. Switch off ignition and secure engine against unintentional operation. Secure aircraft against unauthorized operation. Disconnect negative terminal of aircraft battery.

▲ **WARNING:** Perform work on a cold engine only.

▲ **WARNING:** Should removal of a locking device (namely lock tabs, self-locking fasteners) be required when undergoing disassembly/assembly, always replace with a new one.

◆ **NOTE:** All work has to be performed in accordance with the relevant Maintenance Manual.

3.1) Instructions

3.1.1) Modifying the cap

The plastic plug screw in the overflow bottle must be reworked according to one of the two following options.

▲ **WARNING: Danger of scalding!**

Perform the rest of the instructions only when the engine is cold.

◆ **NOTE:** There are two options to choose from to enlarge the vent hole.

You should ideally use the option number 2 with a hose nipple and hose to be able to drain the existing coolant vapor overboard in case of overheating.

- Unscrew cap (2) from the overflow bottle.

3.1.2) Option 1

(see fig. 1)

- Bore the existing vent hole from dia. 1mm (0.04 in.) to dia. 2.5mm (0.1 in.)
- Screw the cap onto the overflow bottle.

3.1.3) Option 2

(see fig. 2 to 5)

- Bore the existing vent hole from dia. 1mm (0.04 in.) to dia. 6mm (0.236 in.)
- Apply LOCTITE[®] 603 to the threads of the hose nipple (3).
- Insert nipple (3) into the vent hole.
- Install nut (1) onto the hose nipple (3). Tightening torque 5 Nm (44 in lb).
- Screw the cap onto the overflow bottle.

Steps to attach the hose:

- Attach the hose with a gear-type hose clamp (4).
- Make sure the hose (5) has no kinks. Route it overboard and secure.
- Restore aircraft to original operating configuration.
- Connect negative terminal of aircraft battery.

3.2) Test run

Conduct test run including ignition check and leakage test.

3.3) Summary

These instructions (section 3) have to be conducted in compliance with section 1.5.

Approval of translation to best knowledge and judgement - in any case the original text in the German language and the metric units (SI-system) are authoritative.

4) Appendix

The following drawings should provide additional information:

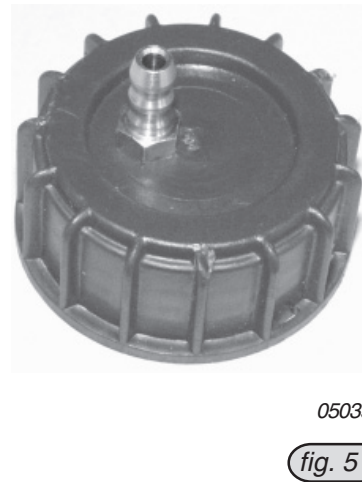
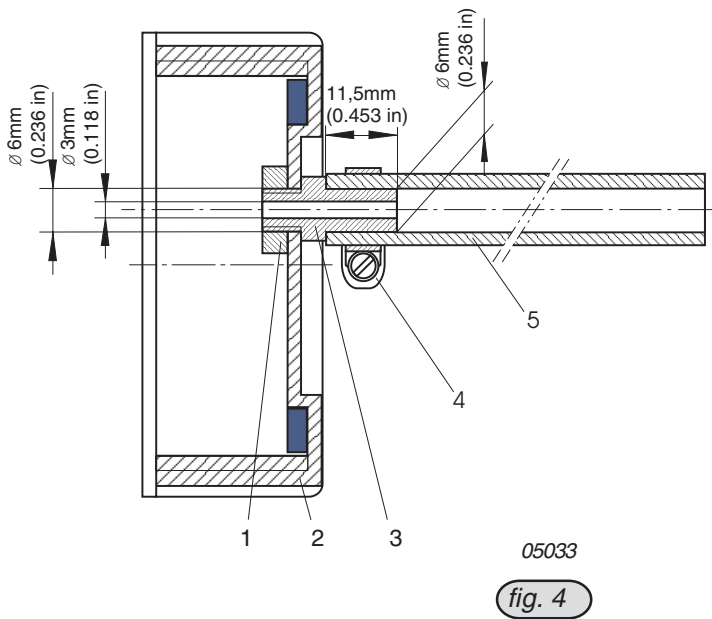
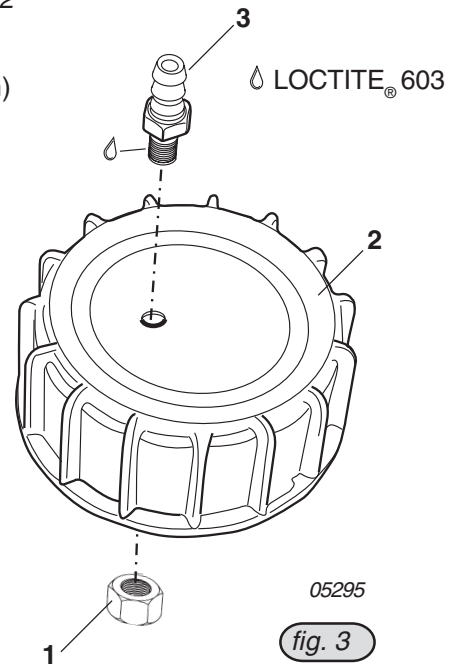
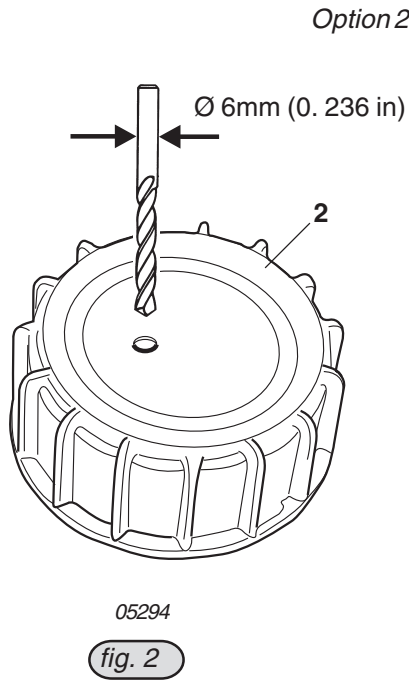
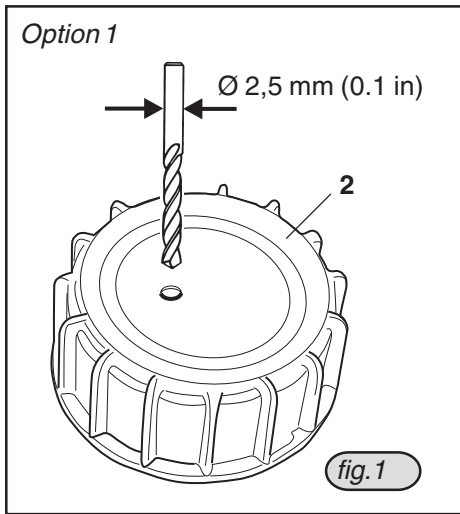

◆ NOTE: The illustrations in this document show the typical construction. They may not represent full detail or the exact shape of the parts which have the same or similar function. Exploded views are **not technical** drawings and are for reference only. For specific detail, refer to the current documents of the respective engine type.