

Replacement of electrical fuel pump(s) for ROTAX® Aircraft Engines

ATA System: 73-10-00 Fuel system

MANDATORY

1) Planning information

To obtain satisfactory results, procedures specified in this publication must be accomplished with accepted methods in accordance with prevailing legal regulations.

BRP-Rotax GmbH & Co KG cannot accept any responsibility for the quality of work performed in accomplishing the requirements of this publication.

1.1) Applicability

NOTE: Make sure to check the whole set of criteria mentioned in this section.

The following single fuel pumps (with S/N listed below) may be installed in all versions of ROTAX® engine types 912 i and 915 i A Series and/or accessory/spare parts/fuel pump modules.

Fuel pump serial number:

Fuel pump	Description	Serial number
Part no. 889694*	Fuel pump	from S/N 180500 up to S/N 203724 inclusive

*) supplier part number

See [Fig. 1](#) and [Fig. 2](#) for information on how to find the part no. and S/N on the fuel pump assy.

NOTE: Fuel pumps with serial number (S/N) lower or higher than the range listed above are not affected.

NOTE: Fuel pump assemblies that have been re-worked (see e.g. relevant logbook entry and/or verify by a visual check of serial numbers) are affected and need a replacement when above serial numbers (S/N) are installed.

General

NOTICE

Please also contact the aircraft manufacturer for possible further aircraft related information and requirements related to this accessory part.

SERVICE BULLETIN

1.2) Concurrent ASB/SB/SI and SL

In addition to this Service Bulletin the following documents must be observed and complied with:

- in general all relevant Alert Service Bulletins (ASB), Service Bulletins (SB), Service Instructions (SI), Service Letters (SL), Service Instruction - Parts and Accessories (SI-PAC) with relevance to perform this maintenance, repair or overhaul task.
- Alert Service Bulletin - ASB-915 i-008/ASB-912 i-011, title "Replacement of fuel pump assy.", current issue.
- Alert Service Bulletin - ASB-912 i-010/ASB-915 i-006, title "Inspection and/or replacement of fuel pump assy.", current issue.
- Service Instruction - SI-912 i-019/SI-915 i-005, title "Introduction of revised fuel pump assy.", current issue.
- Service Instruction - SI-912 i-025, title "Fuel pump assembly", current issue.
- Service Instruction - Parts and Accessories - SI-PAC-016, title "Fuel pump assembly", current issue.

1.3) Reason

Due to deviations in the manufacturing process of the electric fuel pump, a malfunction of fuel supply may occur. Possible effect in flight might be a loss of the redundancy within the fuel pump system. On ground the failure might be detected during the run-up check.

1.4) Subject

Replacement of electrical fuel pump(s) for ROTAX® Aircraft Engines.

1.5) Compliance

- On undelivered engines/spare parts prior to delivery
- Before the initial installation of the engine and/or spare part
- Carry out this replacement of the fuel pump assemblies listed in section 1.1., according to the instructions in Chapter 3 at the next ROTAX® scheduled maintenance event, but at the latest after 1 year (from the date of the initial issue of this Service Bulletin)



Non-compliance with these instructions could result in engine damages, personal injuries or death.

1.6) Approval

The technical content of this document is approved under the authority of the DOA ref. EASA.21J.048.

SERVICE BULLETIN

1.7) Labor time and credit

A labor credit will be provided for work performed by a technician with current applicable iRMT rating.

Work performed	iRMT rating required	Labor credit
Replacement of both single fuel pumps in fuel pump assy. as per Chapter 3 on engine and already installed.	iRMT Maintenance Service* or Heavy	1.5 hours**

* For an iRMT Maintenance Service rated maintenance technician in this specific case an approval by a ROTAX® Authorized Distributor or their independent Service Centers must be given to ensure that the maintenance technician is capable of such work.

** in this case no labor will be covered for engine test run as this work is anyhow performed in course of a standard maintenance event.

To apply for labor credit, contact your ROTAX® Authorized Distributor or their independent Service Centers.

1.8) Mass data

Change of weight - - - none.
 Moment of inertia - - - unaffected.

1.9) Electrical load data

No change.

1.10) Software modifications

No change.

1.11) References

In addition to this technical information refer to current issue of

- in general Illustrated Parts Catalog (IPC) and in particular: Chapter 73-10-00
- in general Operators Manual (OM)
- in general Installation Manual (IM)
- in general Maintenance Manual Line (MML)
- in general Maintenance Manual Heavy (MMH) and in particular: Chapter 73-10-00

NOTE: The status of the Manuals can be determined by checking the table of amendments. The 1st column of this table shows the revision status. Compare this number to the one listed on the ROTAX website:
www.flyrotax.com. Updates and current revisions can be downloaded for free.

1.12) Other Publications affected

None.

1.13) Interchangeability of parts

- All affected and removed fuel pumps cannot further be used and must be marked unserviceable. These parts must be returned FCA (Free CArrier) to ROTAX® Authorized Distributors or their independent Service Centers

d06937.fm

SERVICE BULLETIN

2) Material Information

2.1) Material

Price and availability will be provided on request by ROTAX® Authorized Distributors or their independent Service Centers.

2.2) Company support information

- Any possible support by BRP-Rotax will be provided on request by ROTAX® Authorized Distributors or their independent Service Centers
- Exchanged parts must be returned FCA (Free CArrier) to ROTAX® Authorized Distributors or their independent Service Centers
- This exchange program and cost sharing is valid until the date set in the compliance in section 1.5). Up to this date limited reimbursement of costs can be applied for
- Shipping costs, downtime costs, loss of income, telephone costs etc. or costs of conversion to other engine versions or additional work, as for instance simultaneous engine overhauls are not covered in this scope and will not be borne or reimbursed by ROTAX®

2.3) Material requirement and credit per engine

None.

2.4) Material requirement and credit per spare part

Parts requirement in case of replacement:

Replacement of both single fuel pumps in fuel pump assy.		
part no.	Description	
481377		Fuel pump exchange kit
consists of:		
	201160	Rubber grommet (2x)
	951128	1-Ear-clamp 36.4-39.6 mm (2x)
	951773	1-Ear-clamp 14.6-17.8 mm (12x)
	853313	1-Ear-clamp 17.8-21 mm (4x)
	974050	Fuel hose (6x)
	974060	Fuel hose (2x)
	889691	Fuel pump (2x)

2.5) Rework of parts

None.

SERVICE BULLETIN

2.6) Special tooling/lubricants- /adhesives- /sealing compounds

Price and availability will be supplied on request by ROTAX® Authorized Distributors or their independent Service Centers:

Part no.	Description	Application
-	CRC Leak Detector (14503)*. Non-flammable water based formula. No oils, silicones or harmful solvents.	Crimp connection leak detection.
-	BERNER Leckfinder (148383)*. Water based formula, non-corrosive, silicone free.	Crimp connection leak detection.

*) or equivalent

NOTE: There are many third party commercial leak detection products available. Ensure that the leak detection solution used is non-corrosive and does not contain harmful solvents.

NOTICE If using these special tools and adhesives, observe the manufacturer's directions.

SERVICE BULLETIN

3) Accomplishment/Instructions

- ROTAX® reserves the right to make any amendments to existing documents, which might become necessary due to this standardization, at the time of next revision or issue.

NOTE: Before accomplishment, review the entire documentation to make sure you have a complete understanding of the procedure and requirements.

Accomplishment

All measures must be implemented and confirmed by at least one of the following persons or organizations:

- ROTAX® - Authorized Distributors or their independent Service Centers
- Persons approved by the respective Aviation Authorities
- Persons with approved qualifications for the corresponding engine types. Only authorized persons (iRMT, Level Heavy Maintenance) are entitled to carry out this work



All work has to be performed in accordance with the relevant ROTAX® Instructions for Continued Airworthiness (ICA) of the respective engine type.

General

Further material on general inspection, maintenance and repair can also be found in relevant Advisory Circular AC 43.13 from FAA.

Advisory Circular

The Advisory Circular (AC) contains maintenance methods, techniques and practices.

Procedure

Step	Procedure
1	Check the engine logbook and maintenance documentation, if this SB has already been accomplished.

3.1) Illustrated Parts Catalog - related information



See Chapter 73-10-00 of the latest Illustrated Parts Catalog (IPC) for the respective engine type.

3.2) Installation - related information



See current Installation Manual (IM) for the respective engine type.

3.3) Operation - related information



See current Operators Manual (OM) for the respective engine type.

d06937.fm

SERVICE BULLETIN

3.4) Maintenance (Line) - related information



See current Maintenance Manual Line (MML) for the respective engine type.

3.5) Maintenance (Heavy) - related information



For removal, disassembly/assembly and installation see current Maintenance Manual Heavy (MMH) for the respective engine type.
See also Service Instruction - SI-912 i-025, title "Fuel pump assembly", current issue.

3.5.1) Replacement of both individual affected fuel pumps

See [Fig. 1](#) and [Fig. 2](#).



WARNING

Proceed with this work only in a non-smoking area and not close to sparks or open flames. Switch off ignition and secure engine against unintentional operation. Secure aircraft against unauthorized operation. Disconnect negative terminal of aircraft battery.



WARNING

During work on the fuel distribution system/fuel pump there is a risk of injury due to pressure and fuel! Before starting repair work on the fuel system, ensure that it is no longer pressurized!

ENVIRONMENTAL NOTE

All the operating fluids and cleaning agents can damage the environment if not disposed of properly. Dispose of operating fluids in an Eco-friendly manner!



For removal, disassembly/assembly and installation see current Maintenance Manual Heavy (MMH) for the respective engine type.
See also Service Instruction - SI-912 i-025, title "Fuel pump assembly", current issue.

ENVIRONMENTAL NOTE

Work with the utmost care to ensure that no water pollutants can penetrate into the soil, water or the sewerage system.
Dispose of fuel at the respective collecting point or hand it over to an approved disposal company.

- Restore aircraft to original operating configuration
- Connect negative terminal of aircraft battery

d06937.fm

SERVICE BULLETIN

3.6) Finishing work

Leakage test



See current Maintenance Manual Line (MML) for the respective engine type.
See also Service Instruction - SI-912 i-025, title "Fuel pump assembly", current issue.

3.7) Test run

Conduct test run.

In case of uninstalled engines test run is accomplished with the mandatory test run after installation into aircraft.



Conduct test run.
See Chapter 12-20-00 of the latest Maintenance Manual Line (MML) for the respective engine type.

3.8) Summary

These instructions (Chapter 3) have to be followed in accordance with the deadlines specified in section 1.5.

The execution of the mandatory Service Bulletin must be confirmed in the logbook.

NOTE: Work on EASA certified parts might affect the EASA Form 1 and does require appropriate documentation by authorized persons. Repairs must be entered into the engine logbook and also do apply for the EASA Form 1.

| A revision bar outside of the page margin indicates a change to text or graphic.

Translation into other languages might be performed in the course of language localization but does not lie within ROTAX® scope of responsibility.

In any case the original text in English language and the metric units are authoritative.

3.9) Inquiries

Inquiries regarding this Service Bulletin should be sent to the ROTAX® Authorized Distributor of your area.

A list of all ROTAX® Authorized Distributors or their independent Service Centers is provided on <https://dealerlocator.flyrotax.com>.

SERVICE BULLETIN

4) Appendix

The following illustrations shall provide additional information::

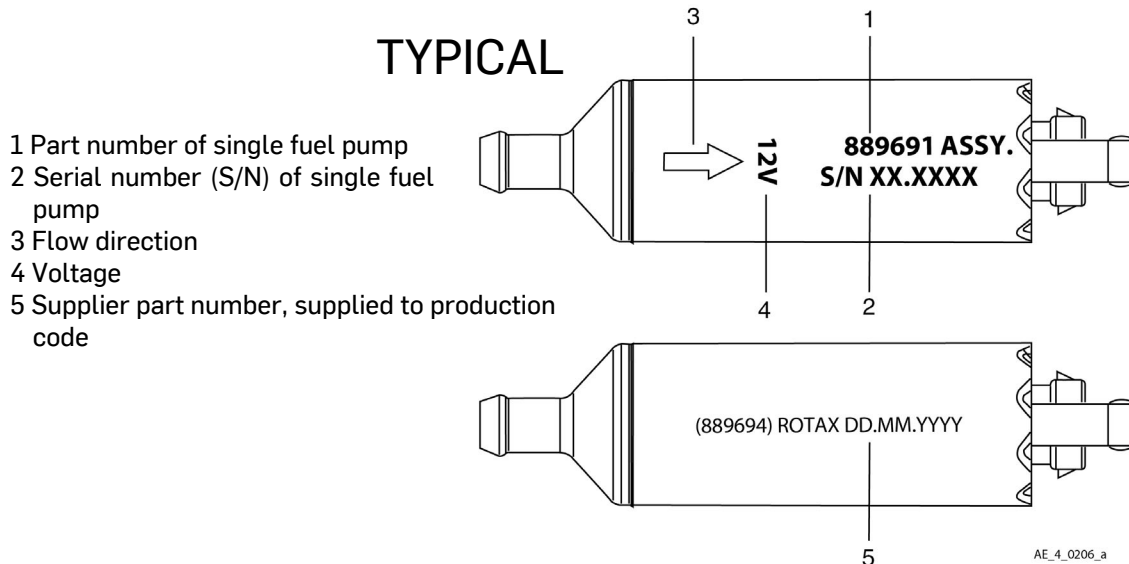

Fig. 1

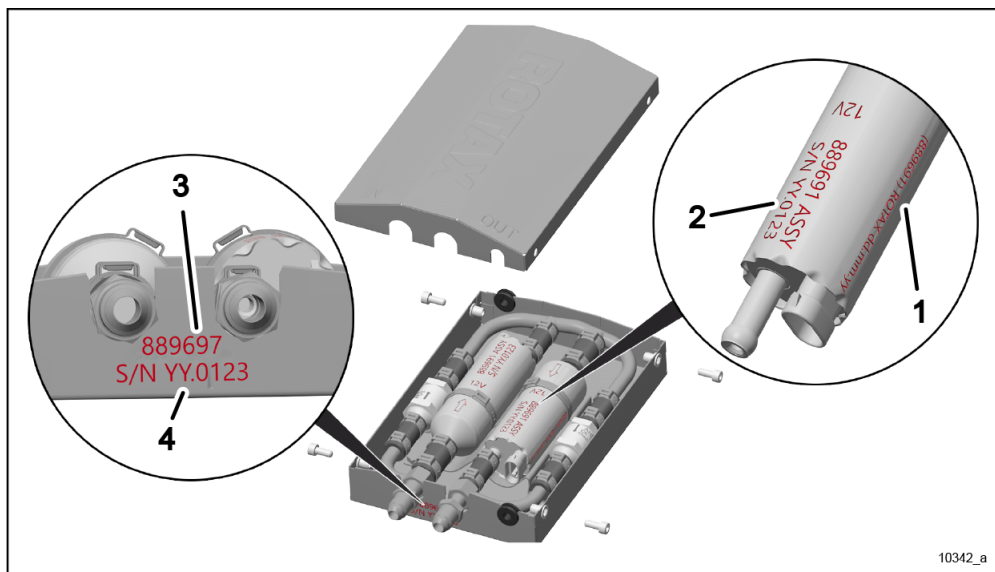

Fig. 2

- 1 Supplier part number, supplied to, production code
- 2 Serial number (S/N) of single fuel pump, see Fig. 1
- 3 Part number of complete fuel pump assy. (889696 for UNF or 889698 for metric)
- 4 Serial number (S/N) of complete fuel pump assy. (housing, fuel pumps,...) example (here e.g. 20.0123)

d06937.fm

SERVICE BULLETIN

NOTE: The fuel pump assembly (including stainless steel box, fuel pumps, check valves and hoses/tubing) serial number may, or may not, be different than the serial number of the individual fuel pumps (See [Fig. 1](#) and [Fig. 2](#)).

Do not modify the assembly serial number that is engraved on the stainless steel housing. This is the assembly serial number and stays the same regardless of the individual fuel pump serial number.

NOTE: The illustrations in this document show the typical construction. They may not represent full detail or the exact shape of the parts which have the same or similar function. Exploded views are not technical drawings and are for reference only. For specific detail, refer to the current documents of the respective engine type.