



ROTAX 508 UL - Valve Cover Attachment

1) General:

This Service Information concerns all 508 UL ROTAX engines up to engine no. 3,707.736. On the subsequent engines, this modification is already integrated.

Because of isolated cracking of the batch ① for cover attachment, the cover screw M6 x25 (part no. 840 861) is to be exchanged for an Allen screw M6x30 DIN 912 (part no. 840 889).

This replacement needs the re-tapping of the M6 thread to a depth of 16,5 mm (see sketch for updated thread details).

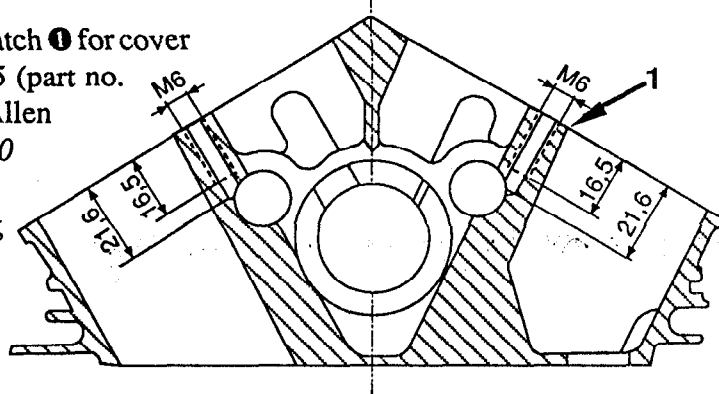

2) Procedure:

- ☞ Remove Allen screw M6x25 ②, sealing ring ③ and valve cover ④ along with O-ring ⑤.
- ☞ Cover engine to prevent any chips reaching valve train.
- ☞ Re-tap thread in the existing 17,6 mm deep blind-end hole, utilizing suitable tap drill.

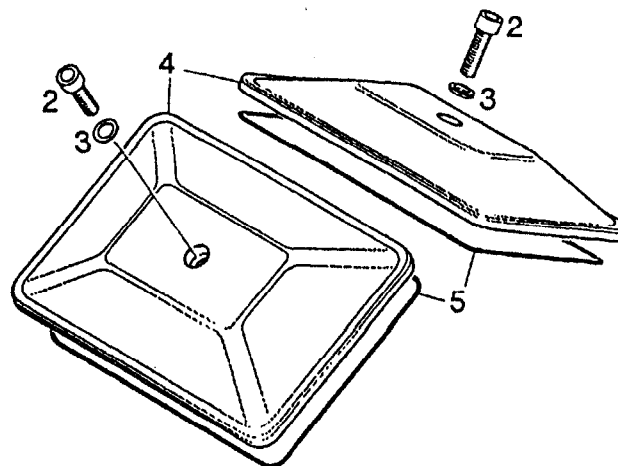

◆ NOTE: For the cutting process use grease to keep chips in the flutes of the tap drill.

- ☞ Check thread depth of 16,5 mm to ensure sufficient attachment of valve cover.
- ☞ Fit O-ring, valve cover, sealing ring along with Allen screw M6x30.
- ☞ Start engine and check for tightness.