

# SERVICE INSTRUCTION - PAC

## Optional fuel pressure damper assy. for ROTAX® Aircraft Engines

ATA System: 73-10-00 Pressure regulator

### 1) Planning information

“PAC” Service Instruction Documents provide detailed information on non-certified ROTAX® Aircraft Engine Parts and Accessories. Referenced parts and accessories are provided without EASA certification or ASTM compliance. Certification / Compliance of referenced Parts and Accessories must be completed by the aircraft OEM.

To obtain satisfactory results, procedures specified in this publication must be accomplished with accepted methods in accordance with prevailing legal regulations.

BRP-Rotax GmbH & Co KG cannot accept any responsibility for the quality of work performed in accomplishing the requirements of this publication.

#### 1.1) Applicability

All ROTAX® Aircraft Engines which are equipped with optional genuine fuel pressure damper assy. part no. 889275 or 889277.

Refer to the latest issue of the relevant Illustrated Parts Catalog.

#### NOTICE

The fuel pressure damper assy. is a part of the fuel system on aircraft-side and not a part of the Engine Type Design. The fuel pressure damper assy. has been tested and released by BRP-Rotax, but it is not certified. The correct function in conjunction with the entire system is the responsibility of the aircraft manufacturer. The certification of the optional fuel pressure damper assy. is the responsibility of the aircraft manufacturer and must be carried out jointly with the aircraft.

#### 1.2) Concurrent ASB/SB/SI and SL

None.

#### 1.3) Reason

An optional fuel pressure damper assy. is available for the fuel inlet side of the fuel system (Fuel rail 1/3 feed line) which reduces fuel pressure fluctuations in certain installations of ROTAX® Aircraft Engines. Fuel pressure damper assy. is available with UNF fuel fitting part no. 889275 or with metric fuel fitting part no. 889277.

#### 1.4) Subject

Optional fuel pressure damper assy. for ROTAX® Aircraft Engines.

#### 1.5) Compliance

NONE - For Information Only.

#### 1.6) Approval

None.

# SERVICE INSTRUCTION - PAC

---

## 1.7) Labor time and credit

Estimated labor hours:

Engine installed in the aircraft - - - labor time will depend on airframe installation and therefore no estimate is available from the engine manufacturer.

## 1.8) Mass data

Change of weight - 0.45 kg (1.0 lb).

Moment of inertia - - - to be calculated by the aircraft manufacturer.

## 1.9) Electrical load data

No change.

## 1.10) Software modifications

No change.

## 1.11) References

In addition to this technical information refer to current issue of

- Illustrated Parts Catalog (IPC)
- Operators Manual (OM)
- Maintenance Manual Line (MML)
- Maintenance Manual Heavy (MMH)

NOTE: The status of the Manuals can be determined by checking the table of amendments. The 1<sup>st</sup> column of this table shows the revision status. Compare this number to that listed on the ROTAX website: [www.flyrotax.com](http://www.flyrotax.com). Updates and current revisions can be downloaded for free.

## 1.12) Other Publications affected

None.

## 1.13) Interchangeability of parts

- All parts are interchangeable

# SERVICE INSTRUCTION - PAC

---

## 2) Material Information

### 2.1) Material- cost and availability

Price and availability will be provided on request by ROTAX® Authorized Distributors or their independent Service Centers.

### 2.2) Company support information

- Any possible support by BRP-Rotax will be provided on request by ROTAX® Authorized Distributors or their independent Service Centers.

### 2.3) Material requirement per engine

See also Illustrated Parts Catalog related information in section 3.1.

Part no.	Qty/engine	Description
889277	as required	Fuel pressure damper assy. - METRIC - Packaged
889275	as required	Fuel pressure damper assy. - UNF - Packaged
941792	1	Allen screw M5x45
841502	1	Allen screw M5x35

### 2.4) Material requirement per spare part

None.

### 2.5) Rework of parts

None.

### 2.6) Special tooling/lubricants- /adhesives- /sealing compounds

None.

# SERVICE INSTRUCTION - PAC

## 3) Accomplishment/Instructions

- ROTAX reserves the right to make any amendments to existing documents which might become necessary due to this standardization, at the time of next revision or issue.

NOTE: Before maintenance, review the entire documentation to make sure you have a complete understanding of the procedure and requirements.

### Accomplishment

All measures must be implemented and confirmed by at least one of the following persons or organizations:

- ROTAX® - Airworthiness representatives
- ROTAX® - Authorized Distributors or their independent Service Centers
- Persons approved by the respective Aviation Authority
- Persons with approved qualifications for the corresponding engine types. Only authorized persons (iRMT, Level Heavy Maintenance) are entitled to carry out this work.

NOTE: All work has to be performed in accordance with the relevant Maintenance Manual.

### 3.1) Spare Parts - related information

Fuel inlet side of the engine (Fuel rail 1/3, feed line)

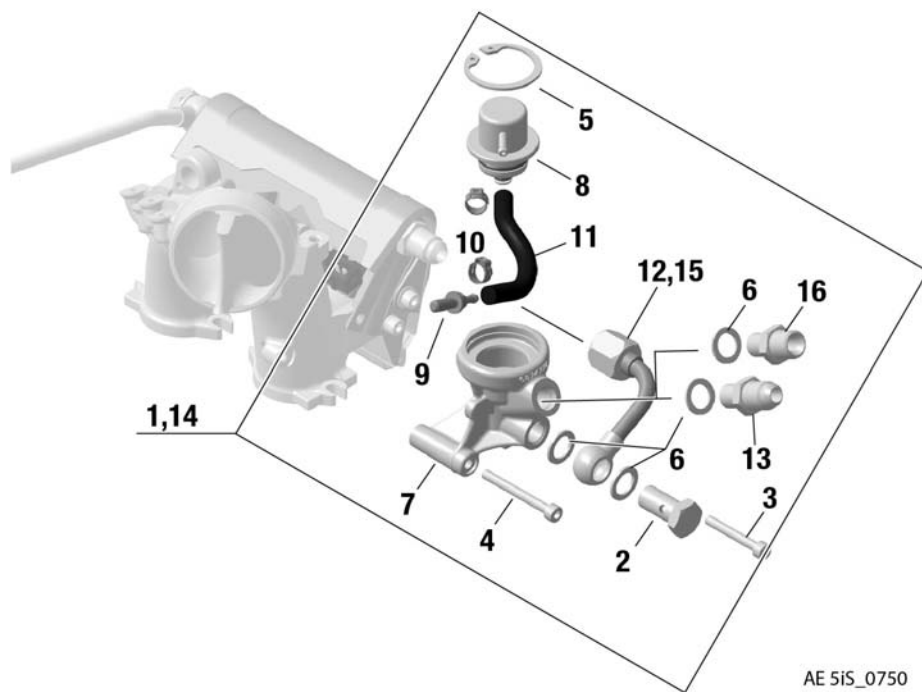

Fig. 1

# SERVICE INSTRUCTION - PAC

Pos.	Description	Part no.	Pos.	Description	Part no.
1 (2-13)	FUEL PRESSURE DAMPER ASSY. UNF - PACKAGED	889275	7	PRESSURE DAMPER HOUSING	874775
2	BANJO BOLT	641541	8	FUEL PRESSURE REGULATOR ASSY.	889262
3	ALLEN SCREW M5x35	841502	9	HOSE NIPPLE M6	840675
4	ALLEN SCREW M5x45	941792	10	1-EAR-CLAMP 8.3 - 10 MM	853653
5	RETAINING RING 36x1.5	845650	11	TUBE 100 +/- 3 MM	960632
6	SEALING RING 12x18	250646	12	FUEL LINE ASSY. 1/3 - UNF	874875
13	ADAPTER 9/16 UNF/ M12x1.5 (AN-6)	840700	15	FUEL LINE ASSY. 1/3 - METRIC	874877
14 (2-11, 15,16)	FUEL PRESSURE DAMPER ASSY. METRIC - PACKAGED	889277	16	ADAPTER M14x1.5/M12x1.5	856821

## 3.2) Installation - related information

### Interface Overview

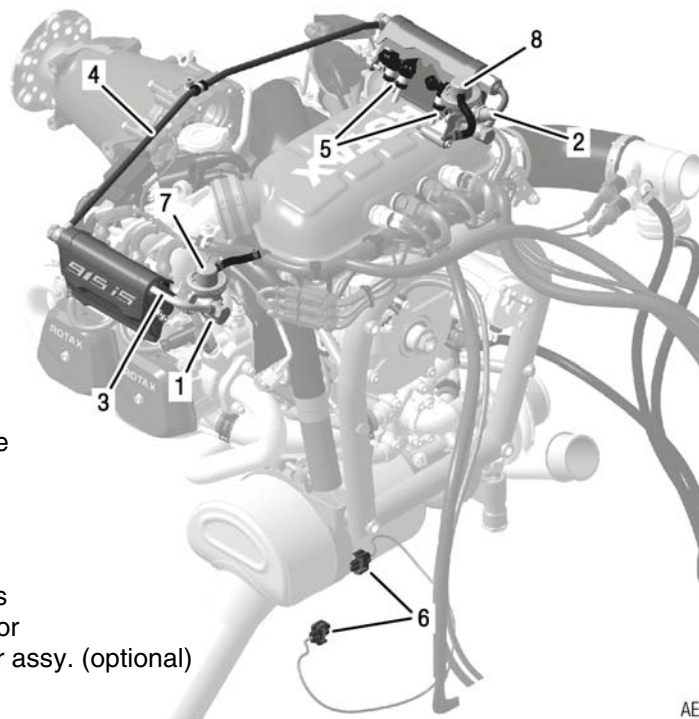

- 1) Fuel rail 2/4 return line
- 2) Fuel rail 1/3 feed line
- 3) Fuel rail
- 4) Fuel line
- 5) Fuel injectors
- 6) Fuel pump connectors
- 7) Fuel pressure regulator
- 8) Fuel pressure damper assy. (optional)

Fig. 2

AE 5iS\_0756

d06758.fm

# SERVICE INSTRUCTION - PAC



See relevant Installation Manual for the respective engine type.

## Fuel inlet

Interface Parameter	Min.	Max.
Fuel pressure (relative to MAP)	2.9 bar (42 psi)	3.1 bar (45 psi)
Acceptable Fuel pressure exceedance (max. 3 sec.)	2.5 bar (36 psi)	3.5 bar (51 psi)
NOTE: Fuel pressure exceedance only allowed after power setting change.		
Fuel pressure oscillation (min. sample rate 20 kHz)	-	1.0 bar (14.5 psi), peak-to-peak
Fuel flow	56 l/h (14.8 gal/h)	120 l/h (31.7 gal/h)

**Connection:** M14x1.5 or AN-6 (9/16-18 UNF).

## Fuel outlet

Interface Parameter	Min.	Max.
Fuel pressure (relative to Fuel Tank pressure)	-	0.5 bar (7.3 psi)

**Connection:** M14x1.5 or AN-6 (9/16-18 UNF).

NOTE: Before accomplishment, review the entire documentation to make sure you have a complete understanding of the procedure and requirements.

### ENVIRONMENTAL NOTE

Work with the utmost care to ensure that no water pollutants can penetrate into the soil, water or the sewerage system.  
Dispose of fuel at the respective collecting point or hand it over to an approved disposal company.

In order to decide if your aircraft design requires a fuel pressure damper assy. follow the following fuel pressure measurement instruction.

#### 3.2.1) Check fuel pressure oscillation

See [Fig. 3](#) up to [Fig. 6](#).

Needed equipment to perform measurement:

- Oscilloscope
- Additional fuel pressure sensor

d06758.fm

# SERVICE INSTRUCTION - PAC

- Adapter piece for fuel pressure sensor (not available from Rotax, if needed manufactured before tests can be done)
- Wiring harness to run additional fuel pressure sensor (not available from Rotax)

Step	Procedure
1	Remove banjo bolt from fuel rail 1/3 (right).

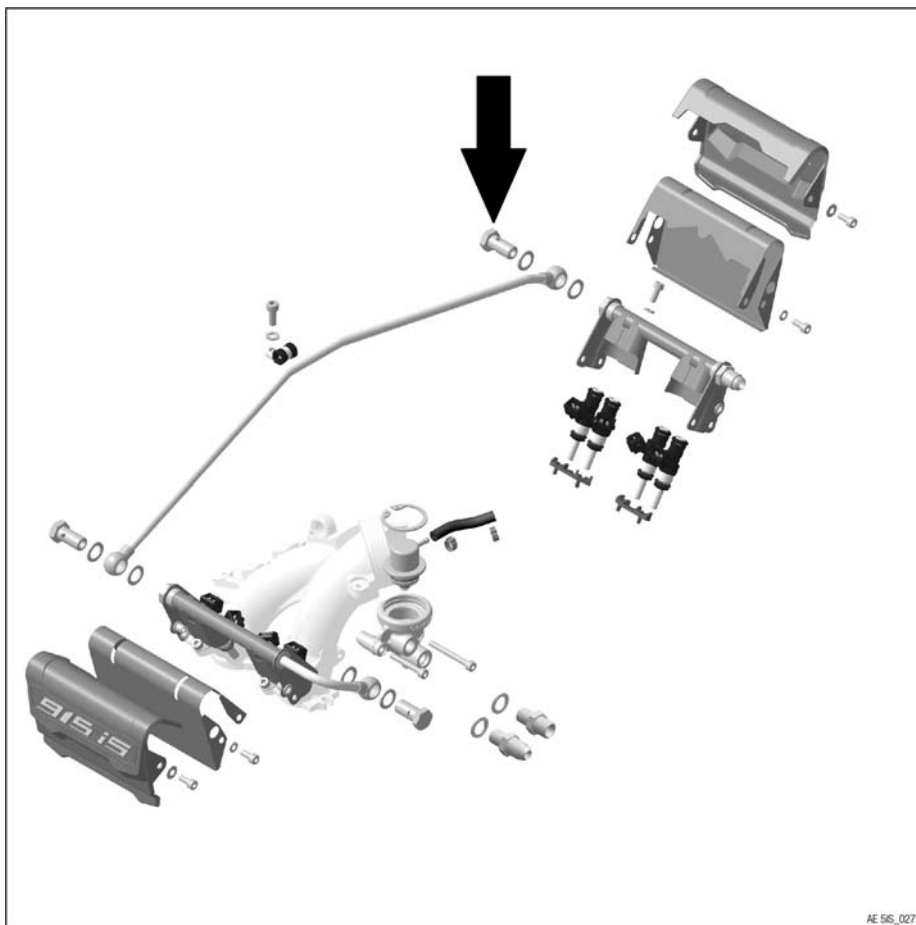

Fig. 3

AE 5iS\_0275\_a

Step	Procedure
2	Install adapter piece (not available as GENUINE ROTAX® spare part) with two gaskets and already attached and torqued pressure sensor part no. 664364. Tightening torque for adapter to fuel rail 1/3 (right): 25 Nm (18 ft. lb).

d06758.fm

# SERVICE INSTRUCTION - PAC

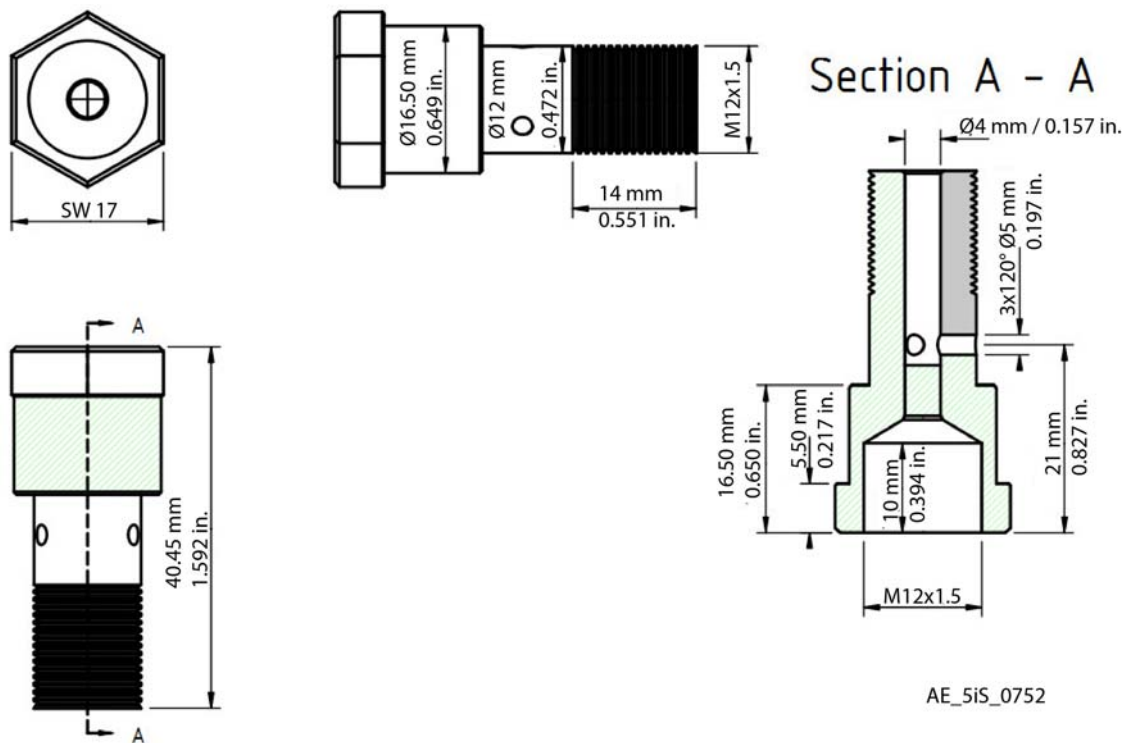

Fig. 4

Step	Procedure
3	Disconnect connector from MAPS 1 sensor and plug this connector into the female connector of the adapter wire harness.
4	Plug male 3 pin connector into temporary sensor attached to fuel rail.

d06758.fm



# SERVICE INSTRUCTION - PAC

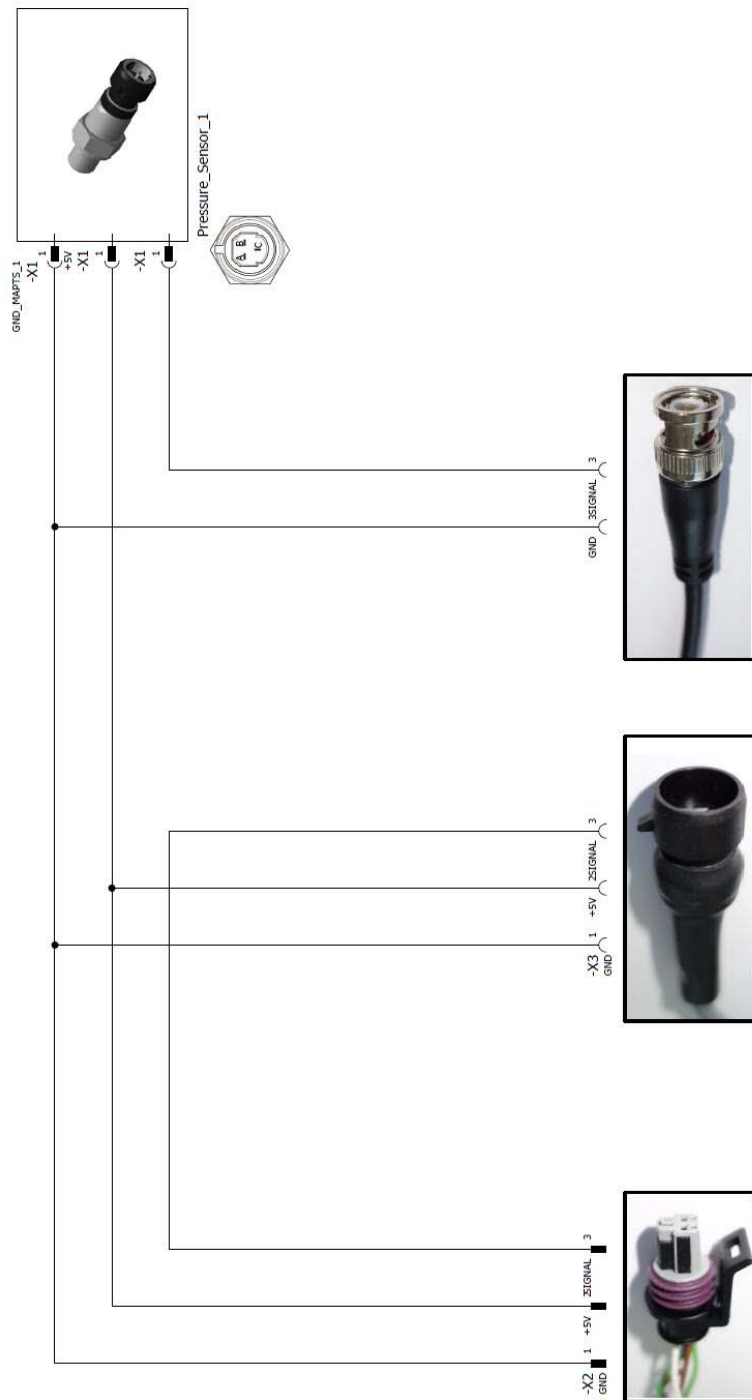

AE\_5iS\_0753

Fig. 5

AE 5iS\_0753

d06758.fm

# SERVICE INSTRUCTION - PAC

See Fig. 6 and Fig. 7.

Step	Procedure
5	Connect wiring harness for pressure sensor supply to oscilloscope.
6	Set oscilloscope to minimum sample rate of 20 kHz.
7	Start engine according to aircraft manufacturing ICA or flight manual.
8	Run engine on idle (for sure between (1700 - 2000 1/min).
9	Check the fuel pressure oscillation. NOTE: Max limit for acceptable oscillation is 1.0 bar (14.5 psi) peak-to-peak.
10	Remove test equipment and restore aircraft to genuine condition.

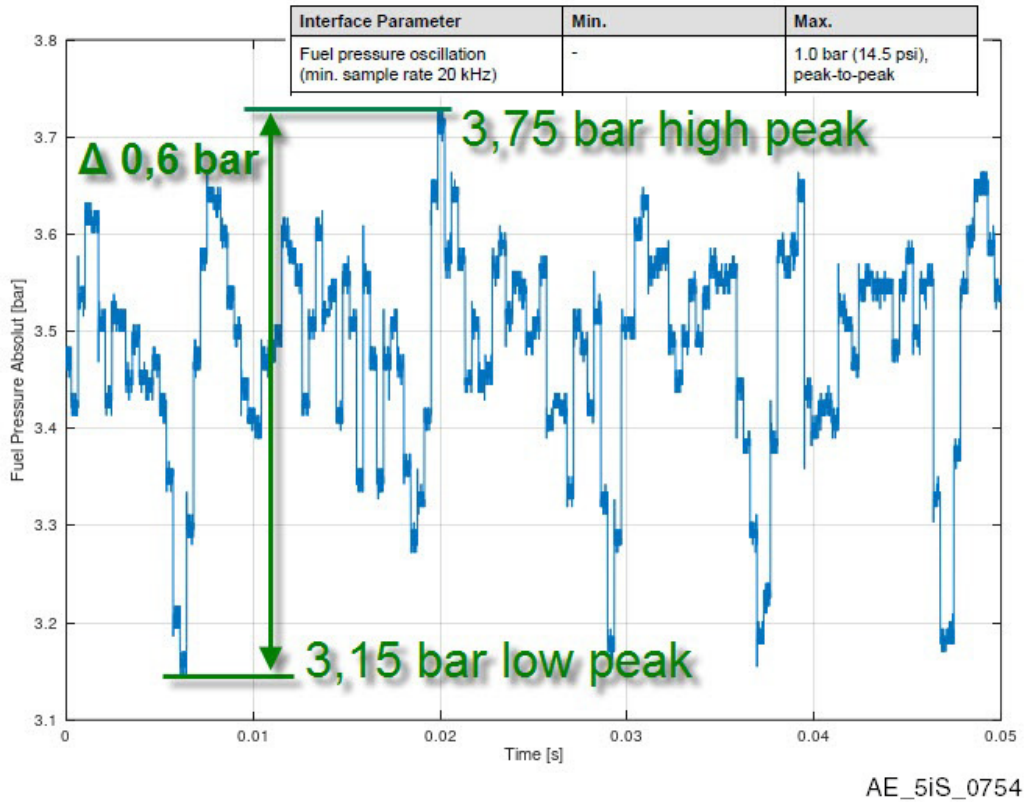

Fig. 6

# SERVICE INSTRUCTION - PAC

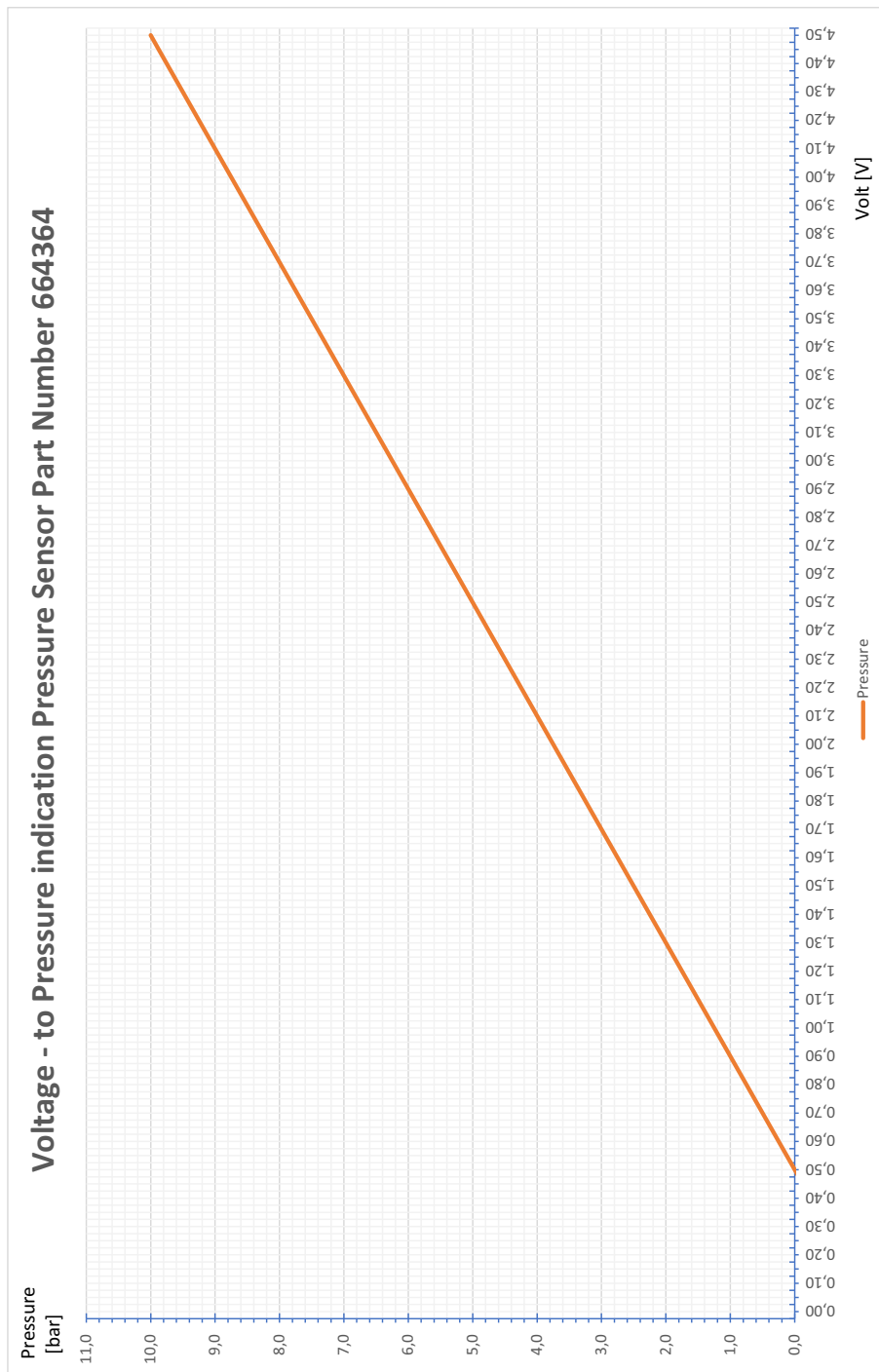

Fig. 7

AE 5iS\_0755

d06758.fm

# SERVICE INSTRUCTION - PAC

## 3.3) Operation - related information

### 3.3.1) Operating instruction



See relevant Operators Manual for the respective engine type.

## 3.4) Maintenance (Line) - related information

Points of inspection	Interval Operating hours		Chapter Reference
	100 h	200 h	
Inspect the fuel system on the engine side for leaks.	X		See relevant Maintenance Manual (Line) for the respective engine type and its periodical maintenance information.
Inspect the fuel system for damages.	X		

## 3.5) Maintenance (Heavy) - related information

### 3.5.1) Installation of the fuel pressure damper assy.

See [Fig. 8](#) up to [Fig. 11](#).

#### **ENVIRONMENTAL NOTE**

Work with the utmost care to ensure that no water pollutants can penetrate into the soil, water or the sewerage system.  
Dispose of fuel at the respective collecting point or hand it over to an approved disposal company.



If the fuel system has already been installed and pressurized, drain the fuel from engine rail. See relevant Maintenance Manual Line Chapter 12-20-00 section Planned maintenance.

Step	Procedure
1	Remove fuel inlet hose (1) from fuel rail 1/3 (right).
2	Remove inside Allen screw M5x12 (2) and lock washer A5 (3) from fuel injector heat shield.

d06758.fm

# SERVICE INSTRUCTION - PAC

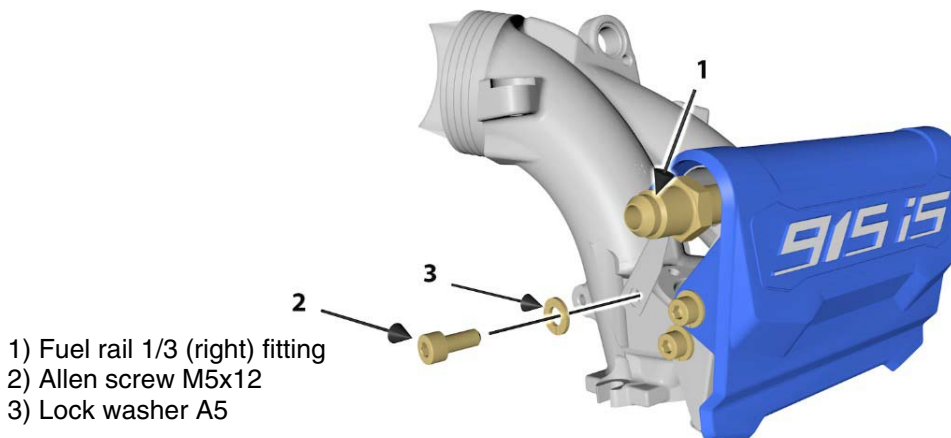

Fig. 8

AE 5iS\_0724

**NOTICE**

Avoid over-tightening the fastening elements. Use a suitable torque wrench for all work.

Step	Procedure
3	Remove the upper-right Torx screw (4) from the throttle body.
4	Place the regulator reference hose threaded fitting (5) with LOCTITE 243 through the separating plate (6) and tighten to 8 Nm (70 in.lb.).

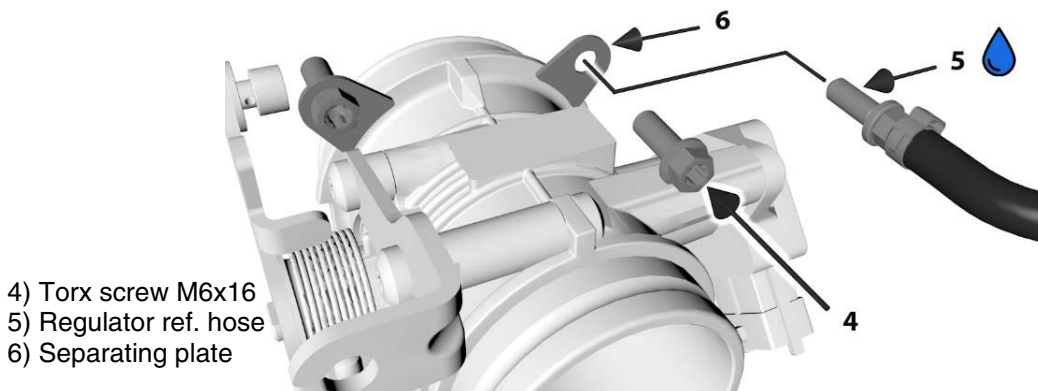

Fig. 9

AE 5iS\_0725

d06758.fm

# SERVICE INSTRUCTION - PAC

Step	Procedure
5	Place the fuel pressure damper assy. into position and attach the fuel inlet fitting (7) finger tight only.
6	Attach the regulator housing to intake manifold 1/3 using Allen screws M5x35 (8) and M5x45 (9) finger tight only.
7	Tighten Allen screws M5 to 5 Nm (44 in.lb.), then tighten fuel fitting to 5 Nm (44 in.lb.).
8	Attach regulator reference hose to threaded fitting.

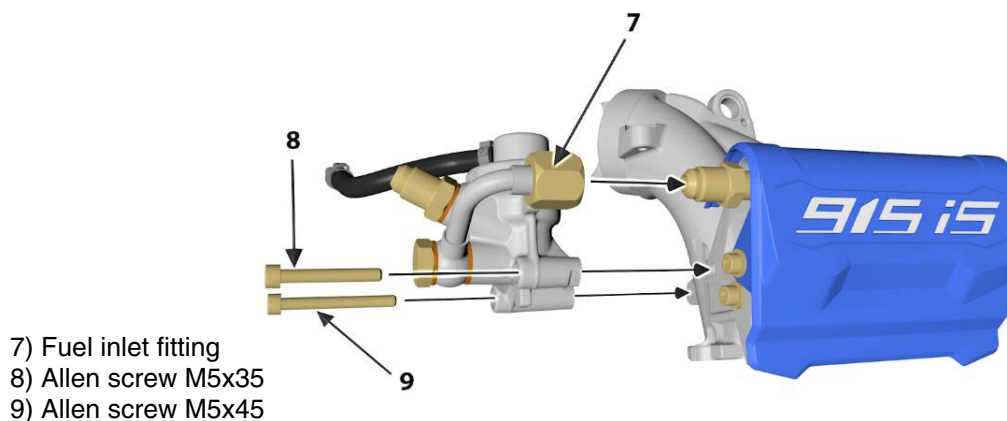

Fig. 10

AE 5iS\_0726

Step	Procedure
9	Fit fuel inlet hose (10) and tighten to 5 Nm (44 in.lb.).
10	Carry out functional check, switch on both fuel pumps. Fuel pressure on pilot display should show: 3.00 bar (43.5 psi) +/- 0.2 bar (+/- 2.9 psi) (differential pressure to the intake manifold pressure or intake air pressure).

d06758.fm

# SERVICE INSTRUCTION - PAC

10) Fuel inlet

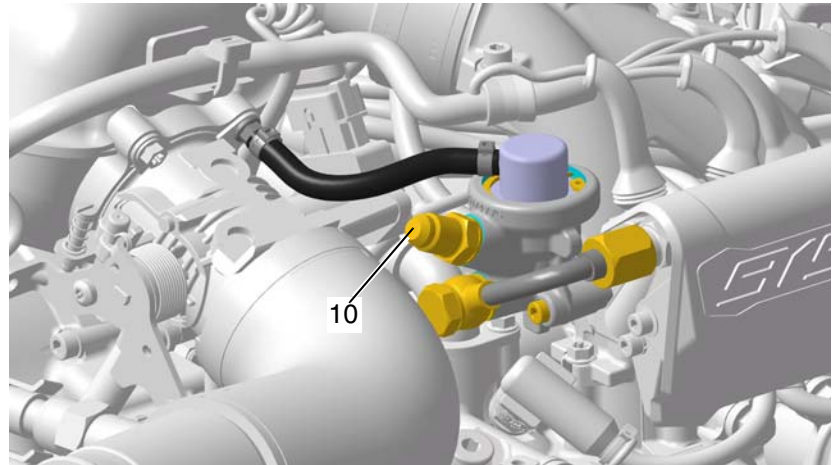

Fig. 11

AE 5iS\_0727

### 3.5.2) Fuel pressure damper assy. - disassembly

Step	Procedure
1	Disconnect the reference hose (1) from the fuel pressure regulator (3).
2	Remove the retaining ring (2) using snap ring pliers without damaging edges of retainer recess.
3	Remove the fuel pressure regulator (3).

- 1) Ref. hose
- 2) Retaining ring
- 3) Fuel pressure regulator

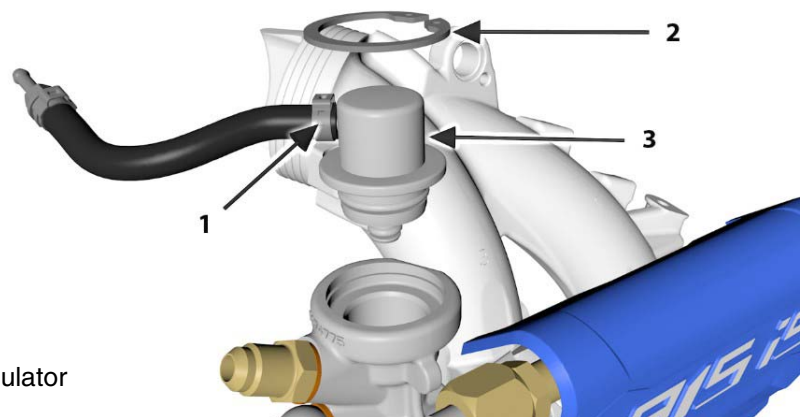

Fig. 12

AE 5iS\_0728

d06758.fm

# SERVICE INSTRUCTION - PAC

## 3.5.3) Fuel pressure damper assy. - inspection

See Fig. 13 and Fig. 14.

Step	Procedure
1	Check all O-rings (1+2). NOTE: If an O-ring is damaged, the entire fuel pressure damper assy. must be replaced. O-rings are not available as spare parts.
2	Check the screen (3) for dirt. NOTE: If the screen is contaminated, the pre-filter must also be checked for function and contamination.

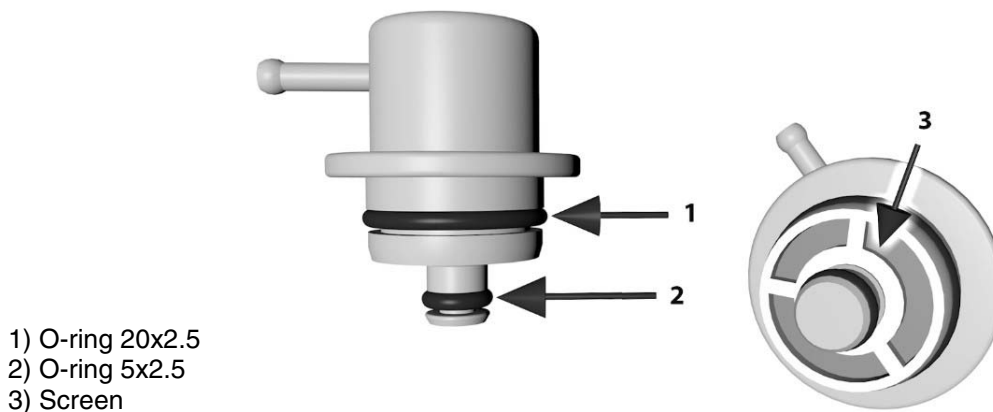

Fig. 13

AE 5IS\_0729

Step	Procedure
3	Check the sealing surfaces of the O-rings (6) for striations.
4	Check the recess of the retaining ring (5) for sharp edges and burrs. NOTE: The recess must not have sharp edges! Sharp edges can be carefully reworked. Make sure that the surface is not getting rougher than before.

d06758.fm



# SERVICE INSTRUCTION - PAC

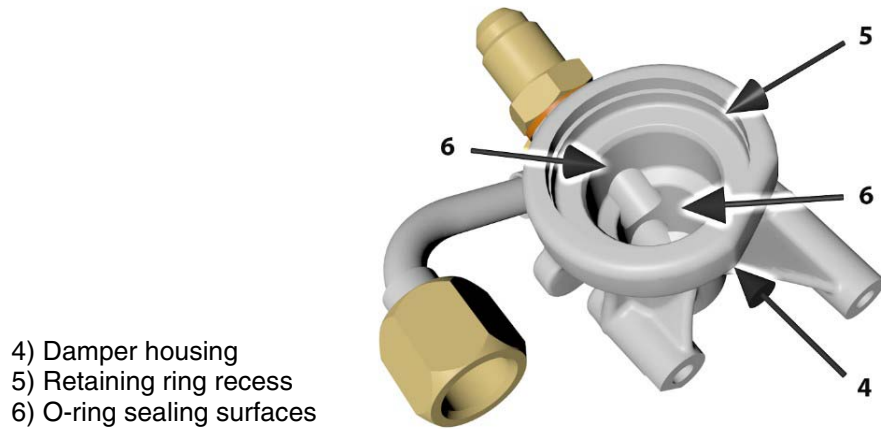

Fig. 14

AE 5iS\_0730

### 3.5.4) Fuel pressure damper assy. - assembly

The fuel pressure damper assy. is assembled and disassembled in the same way. The following should be noted:

Step	Procedure
1	Lubricate the O-rings lightly with lithium based grease.

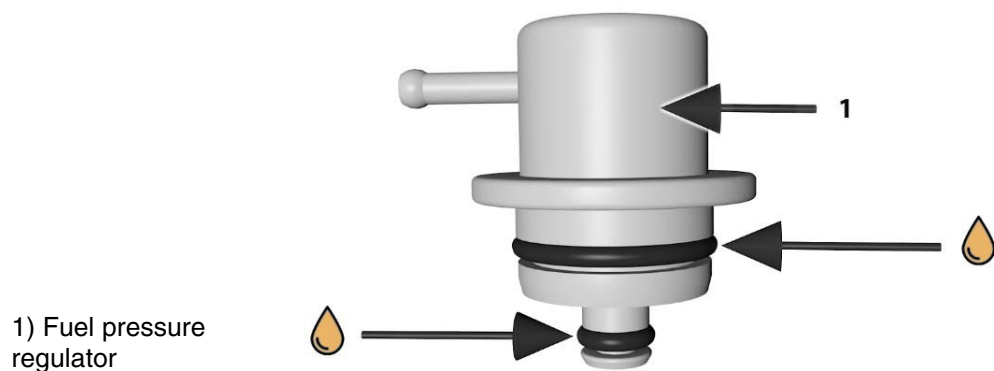

Fig. 15

AE 5iS\_0731

d06758.fm

# SERVICE INSTRUCTION - PAC

See Fig. 16.

Step	Procedure
2	Insert the fuel pressure regulator (2) in the damper housing (4) until it stops.
3	Install the retaining ring (3). NOTE: When the retaining ring is mounted, it must be possible to rotate the fuel pressure regulator manually.
4	Connect reference hose (5) using new one-ear clamp 8.5-10mm.

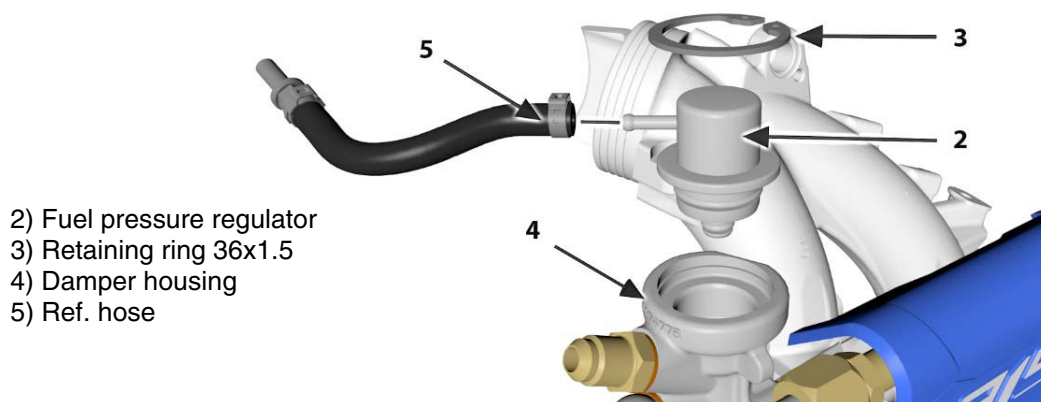

Fig. 16

AE 5iS\_0732

Regarding proper disassembly, assembly, cleaning etc. and further heavy maintenance tasks of the fuel pressure regulator assy. see the aircraft manufacturers instruction for continued airworthiness.

- Restore aircraft to original operating configuration
- Connect negative terminal of aircraft battery

d06758.fm

# SERVICE INSTRUCTION - PAC

---

## 3.6) Test run

In case of uninstalled engines test run can be skipped as this is covered by the mandatory test run after installation.



Conduct test run and perform leakage check. See Chapter 12-20-00 of the latest Maintenance Manual Line for the respective engine type.

## 3.7) Summary

The execution of the Service Instruction - PAC must be confirmed in the logbook.

**|** A revision bar outside of the page margin indicates a change to text or graphic.

Translation into other languages might be performed in the course of language localization but does not lie within ROTAX® scope of responsibility.

In any case the original text in English language and the metric units are authoritative.

## 3.8) Inquiries

Inquiries regarding this Service Instruction - PAC should be sent to the ROTAX® Authorized Distributor of your area.

A list of all ROTAX® Authorized Distributors or their independent Service Centers is provided on [www.FLYROTAX.com](http://www.FLYROTAX.com).

# SERVICE INSTRUCTION - PAC

## 4) Appendix

The following schematics should convey additional information:

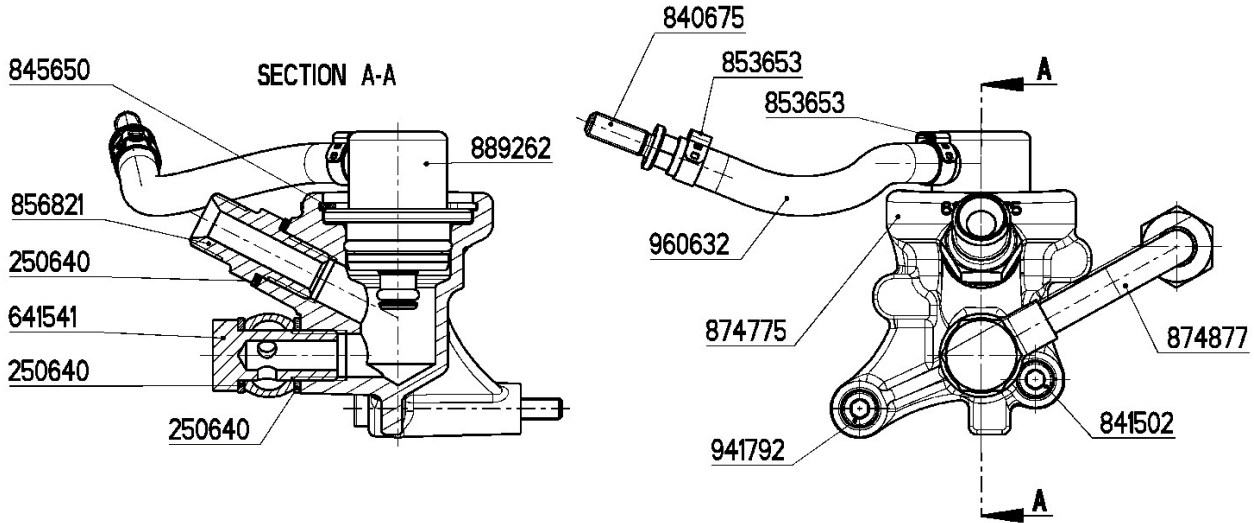

Fig. 17

AE 5iS\_0733

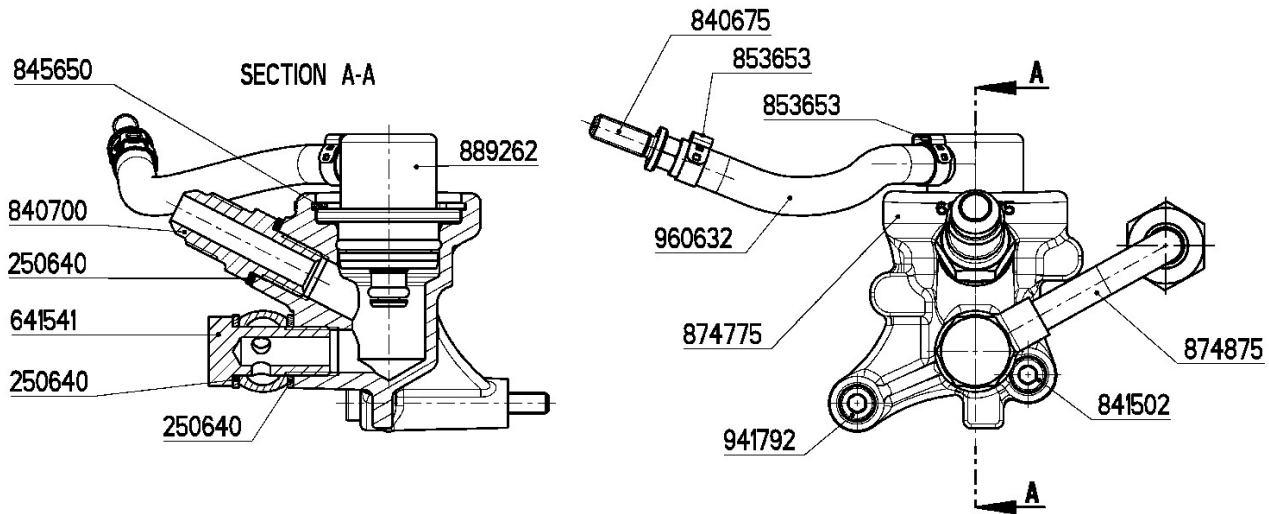

Fig. 18

AE 5iS\_0734

NOTE: The illustrations in this document show the typical construction. They may not represent full detail or the exact shape of the parts which have the same or similar function. Exploded views are **not technical drawings** and are for reference only. For specific detail, refer to the current documents of the respective engine type.

d06758.fm